



04.06.2020



INFORMATION SHEET FOR EUROLOHR VEHICLE COMBINATION

DIMENSIONS AND GERMAN CLARIFICATION REGARDING OVERHANG LOAD SUPPORT

The information, drawings, dimensions and other data contained in this information sheet are provided for information purposes only, without contractual or other obligation and to the exclusion of any liability with regard to the accuracy and completeness of the data. Lohr reserves the right to make changes or additions to the information provided.



- ISO standard 612-1978, definition no. 6.1
- EU Directive 96/53/EC of 25.07.1996
- EU Directive 97/27/EC of 22.07.1997
- EU Directive 2007/46/EC of 09/05/2007
- Regulation (EU) NR.1230/2012 of 12.12.2012
- StVZO:
- §16(1) in connection with §19(1), *sentence* 2 no. 1
- §31d(1) in connection with §32(3) No.1,(4) No.4,(6),(7)



EU TYPE-APPROVALS

DIMENSIONS OF *CAR-CARRIERS* VEHICLE COMBINATIONS

DIMENSIONS OF THE TRAILER AND VEHICLE COMBINATION

No. of EU type approval: e2*2007/46*0082*00 ff

"The vehicle type meets the technical requirements of all the relevant acts specified in Annex IV to Directive 2007/46/EC"

Annex IV item 48/48A: EU Directive 97/27/EC

Length of the vehicle combination max. 18,75 m
(Directive 96/53/EC Annex I No. 1 "Lastzug"; §32(4) No. 4 StVZO)

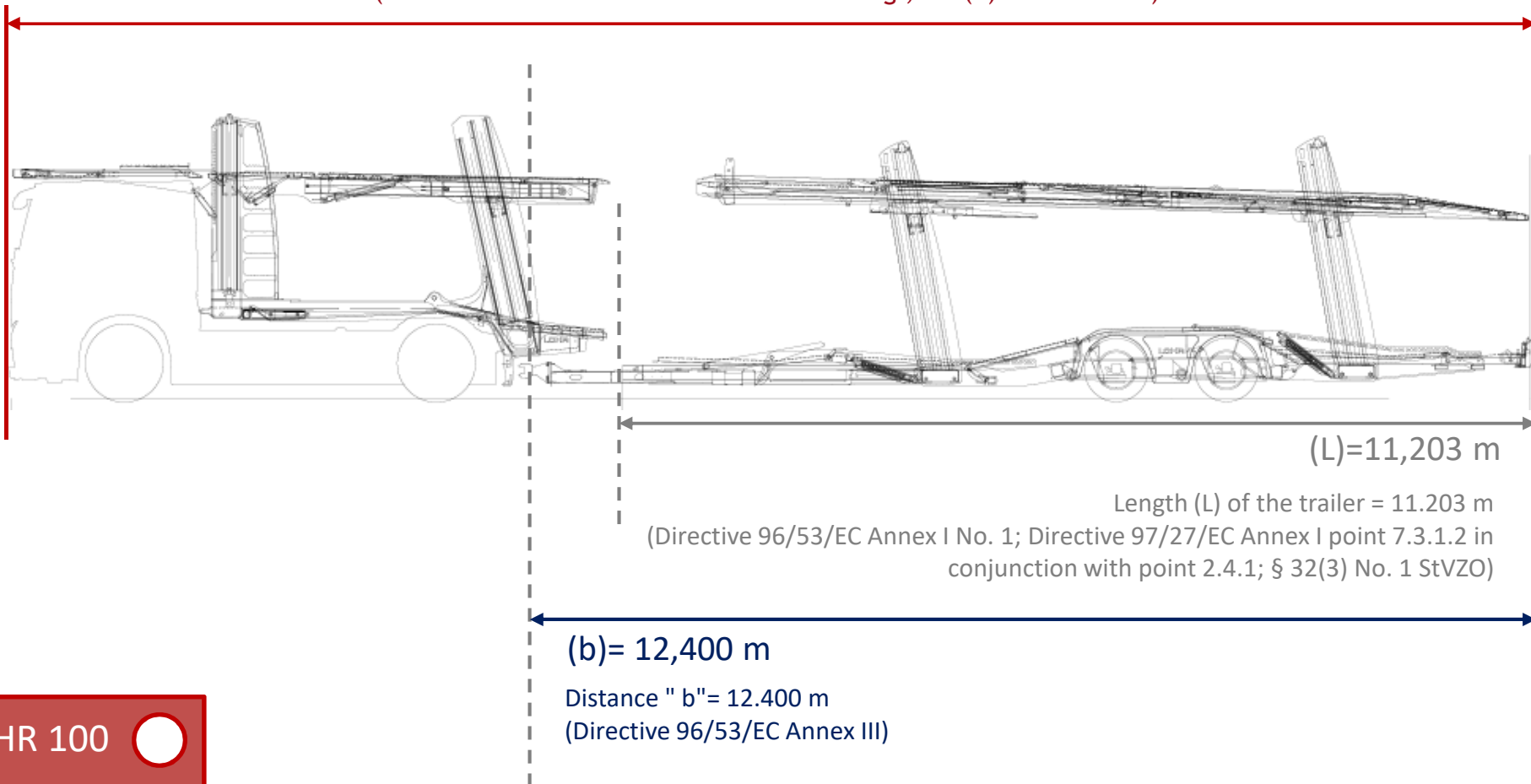

EHR 100



Series built until 31.10.2014

DIMENSIONS OF THE TRAILER AND VEHICLE COMBINATION

No. of EU type approval: e2*2007/46*0201*00 ff

"The vehicle type meets the technical requirements of all the relevant acts specified in Annex IV to Directive 2007/46/EC"

Annex IV item 48/48A: EU Directive 97/27/EC

Length of the vehicle combination max. 18,75 m
(Directive 96/53/EC Annex I No. 1 "Lastzug"; §32(4) No. 4 StVZO)

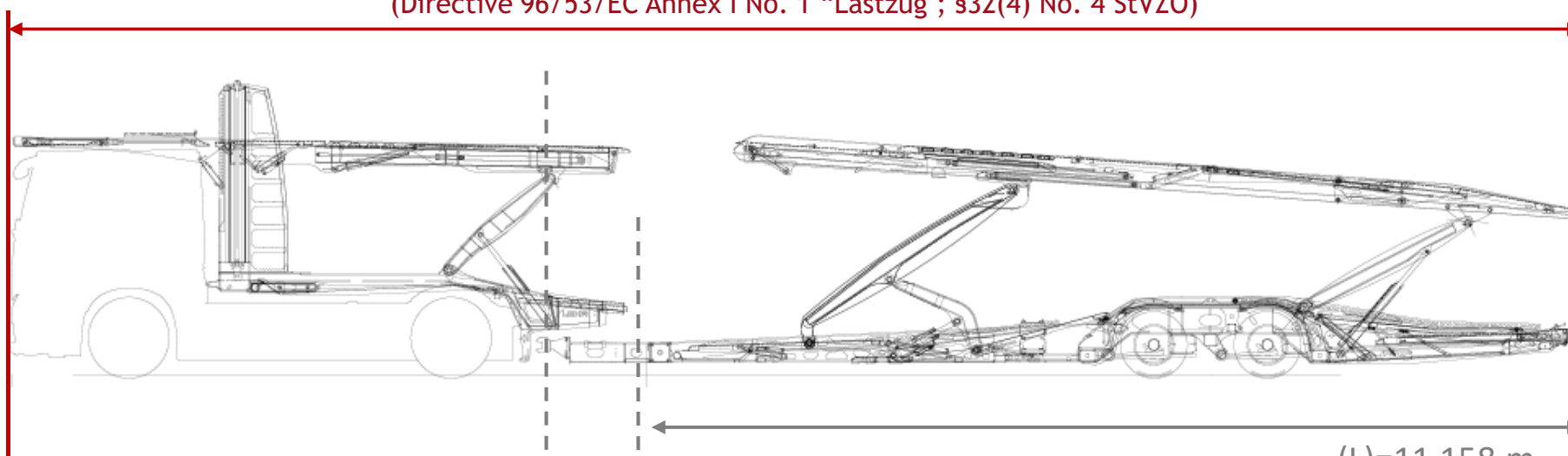

(L)=11,158 m

Length (L) of the trailer = 11.158 m
(Directive 96/53/EC Annex I No. 1; Directive 97/27/EC Annex I point 7.3.1.2 in conjunction with point 2.4.1; § 32(3) No. 1 StVZO)

(b)= 12,400 m

Distance " b"= 12.400 m
(Directive 96/53/EC Annex III)

EHR 200



Series built until 31.10.2014

DIMENSIONS OF THE TRAILER AND VEHICLE COMBINATION

No. of EU type approval: e2*2007/46*0329*00 ff

"The vehicle type meets the technical requirements of all the relevant acts specified in Annex IV to Directive 2007/46/EC"

Annex IV item 48/48A: EU Directive 97/27/EC

Length of the vehicle combination max. 18,75 m
(Directive 96/53/EC Annex I No. 1 "Lastzug"; §32(4) No. 4 StVZO)

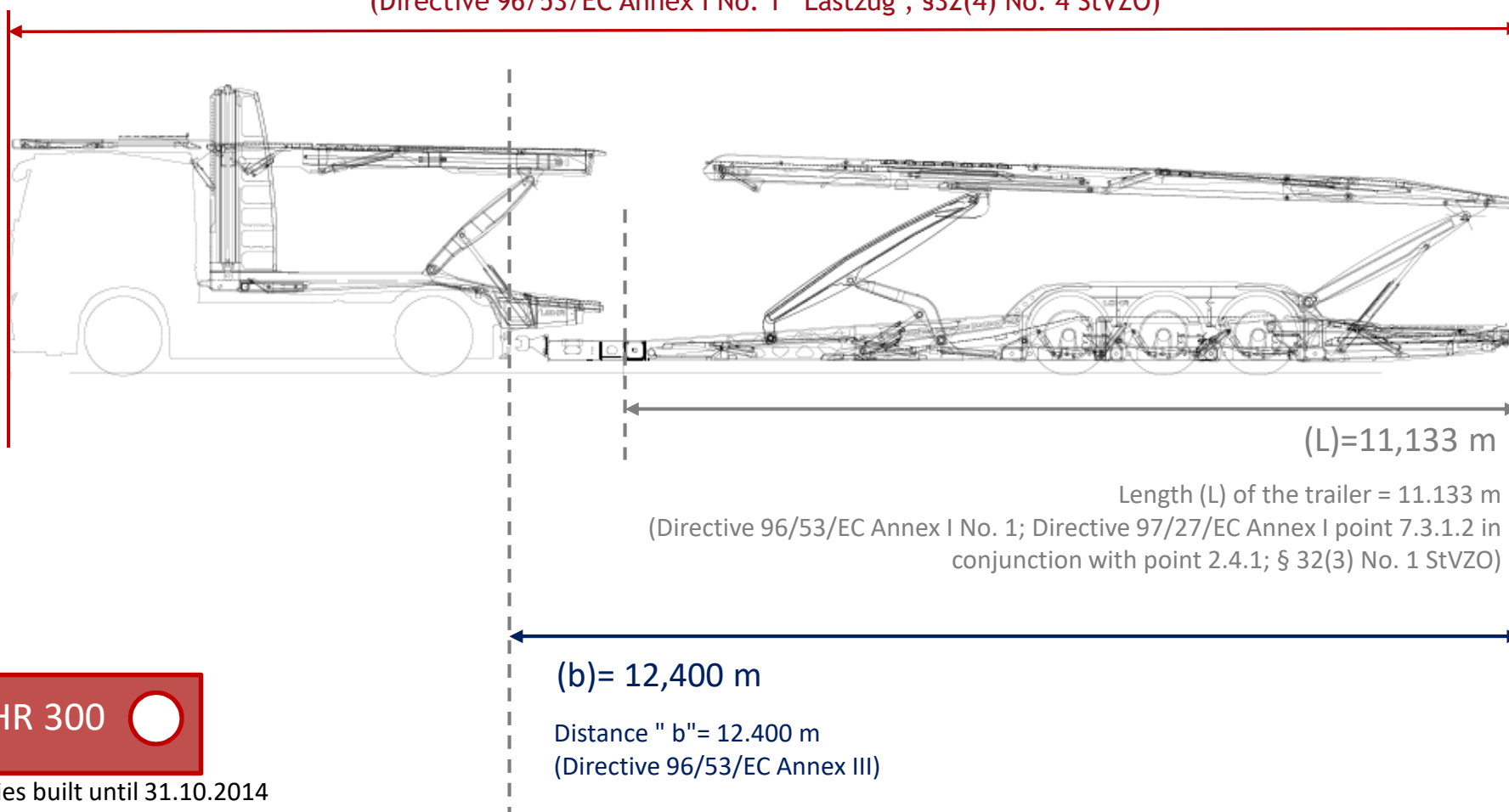

EHR 300



Series built until 31.10.2014

DIMENSIONS OF THE TRAILER AND VEHICLE COMBINATION

No. of EU type approval: e9*2007/46*6237*00 ff

"The vehicle type meets the technical requirements of all the relevant acts specified in Annex IV to Directive 2007/46/EC."

Annex IV, point 48/48A: Regulation (EU) No 1230/2012

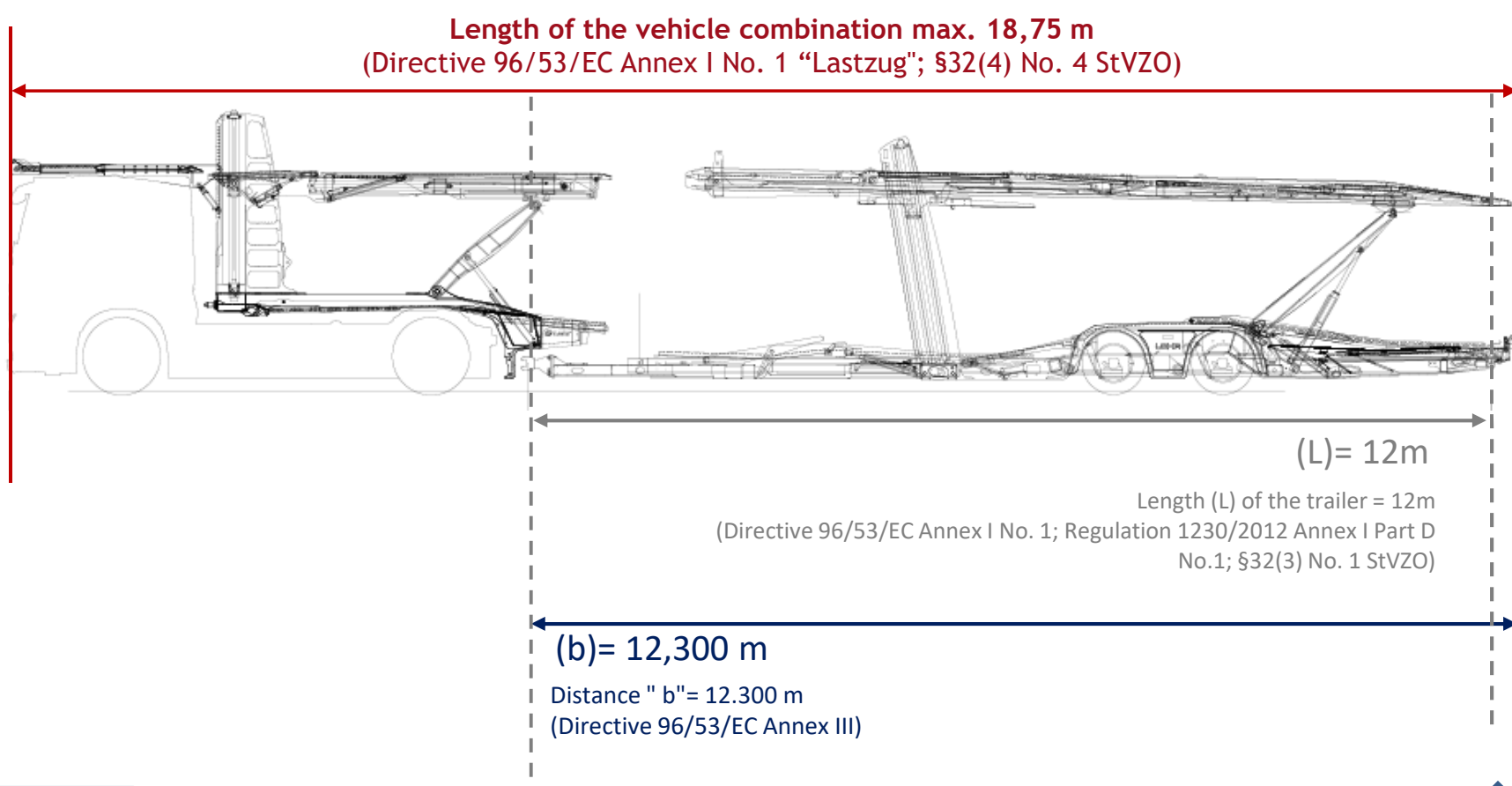

Series built as of 1.11.2014

Regulation (EU) 1230/2012 Annex I Part D No. 1.4
in conjunction with Appendix 1, Table I (in particular Nos. 9, 16, 17)
§32(6) StVZO



DIMENSIONS OF THE TRAILER AND VEHICLE COMBINATION

No. of EU type approval: e2*2007/46*0201*02 ff

"The vehicle type meets the technical requirements of all the relevant acts specified in Annex IV to Directive 2007/46/EC."

Annex IV, point 48/48A: Regulation (EU) No 1230/2012

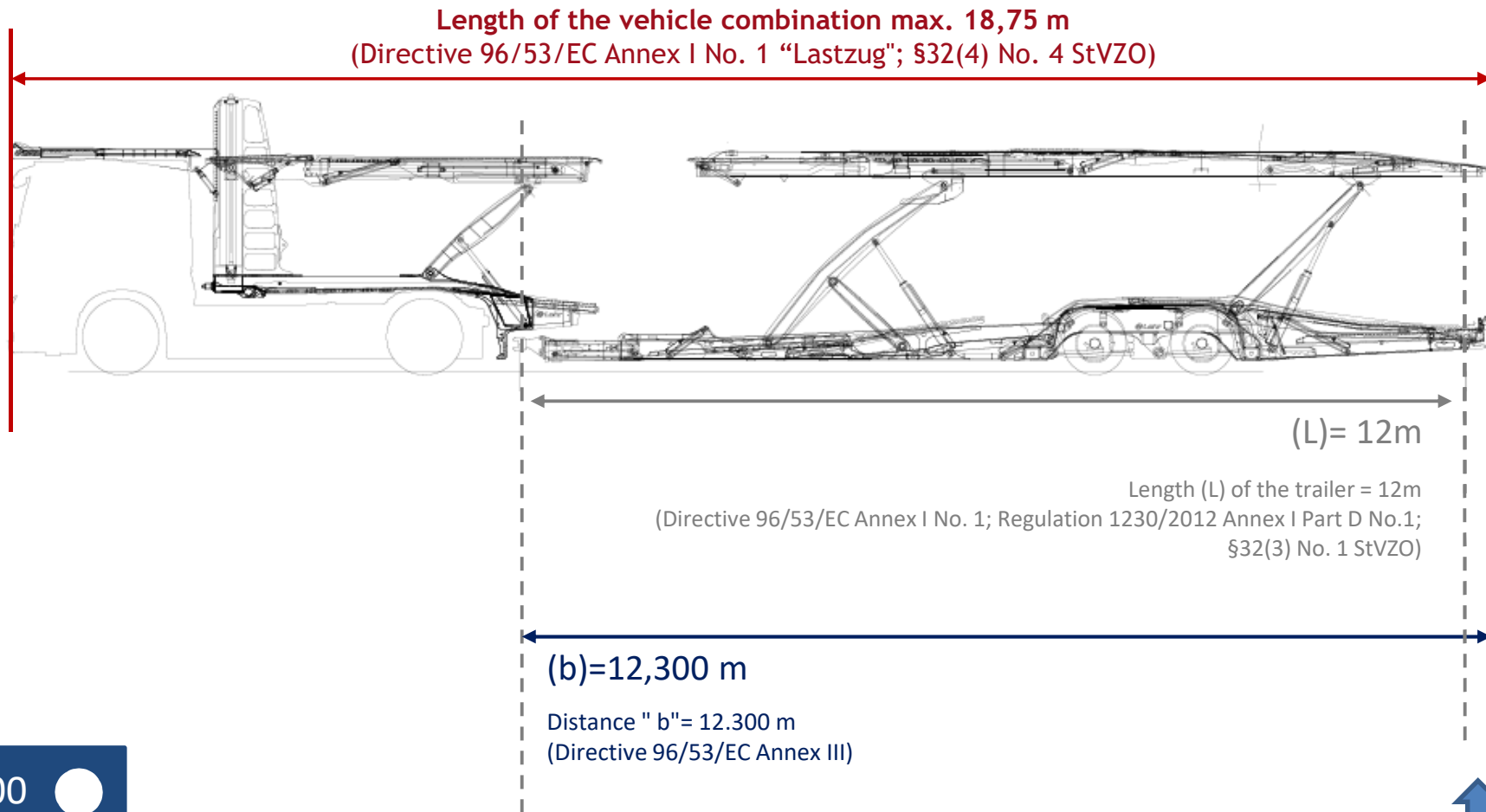

EHR 200



Series built as of 1.11.2014

Regulation (EU) 1230/2012 Annex I Part D No. 1.4
in conjunction with Appendix 1, Table I (in particular Nos. 9, 16, 17)
§32(6) StVZO



DIMENSIONS OF THE TRAILER AND VEHICLE COMBINATION

No. of EU type approval: e2*2007/46*0329*00 ff

"The vehicle type meets the technical requirements of all the relevant acts specified in Annex IV to Directive 2007/46/EC."

Annex IV, point 48/48A: Regulation (EU) No 1230/2012

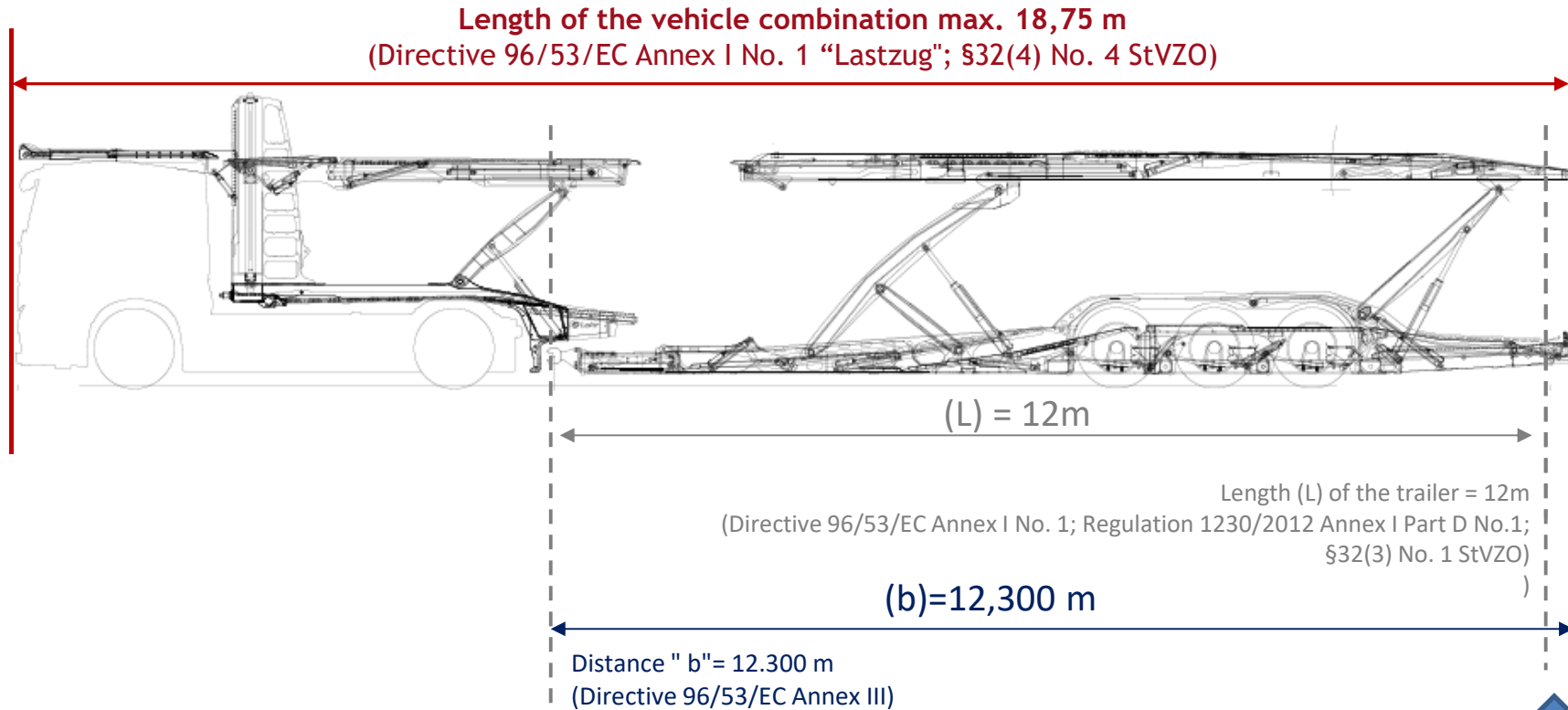

Regulation (EU) 1230/2012 Annex I Part D No. 1.4
in conjunction with Appendix 1, Table I (in particular Nos. 9, 16, 17)
§32(6) StVZO

EHR 300



Series built as of 1.11.2014

DIMENSIONS OF THE TRAILER AND VEHICLE COMBINATION

No. of EU type approval: e9*2007/46*6237*05

"The vehicle type meets the technical requirements of all the relevant acts specified in Annex IV to Directive 2007/46/EC."

Annex IV, point 48/48A: Regulation (EU) No 1230/2012

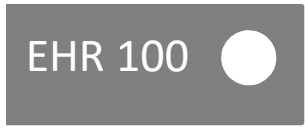
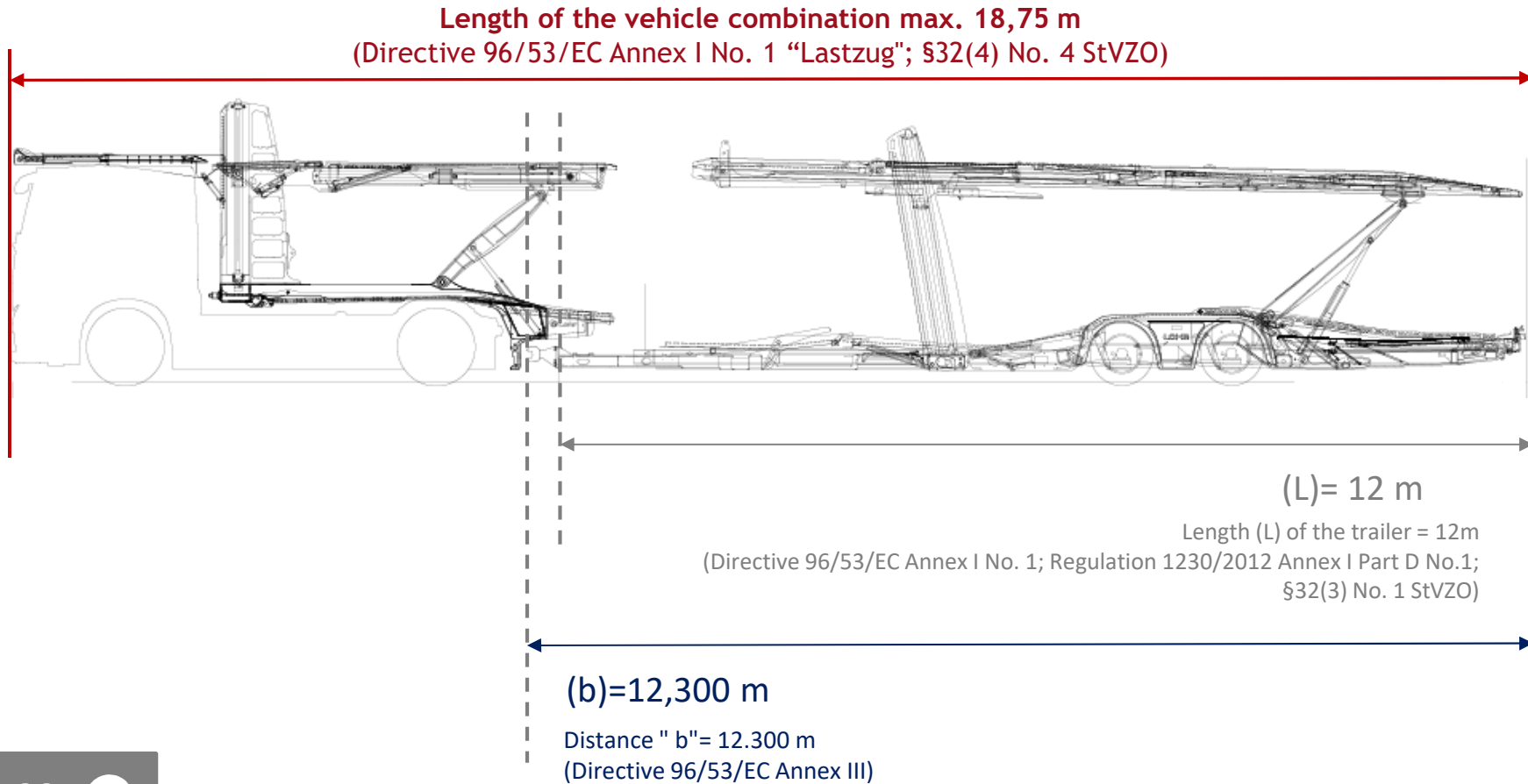

Series built from 2020

DIMENSIONS OF THE TRAILER AND VEHICLE COMBINATION

No. of EU type approval: e2*2007/46*0201*08

"The vehicle type meets the technical requirements of all the relevant acts specified in Annex IV to Directive 2007/46/EC."

Annex IV, point 48/48A: Regulation (EU) No 1230/2012

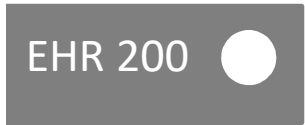
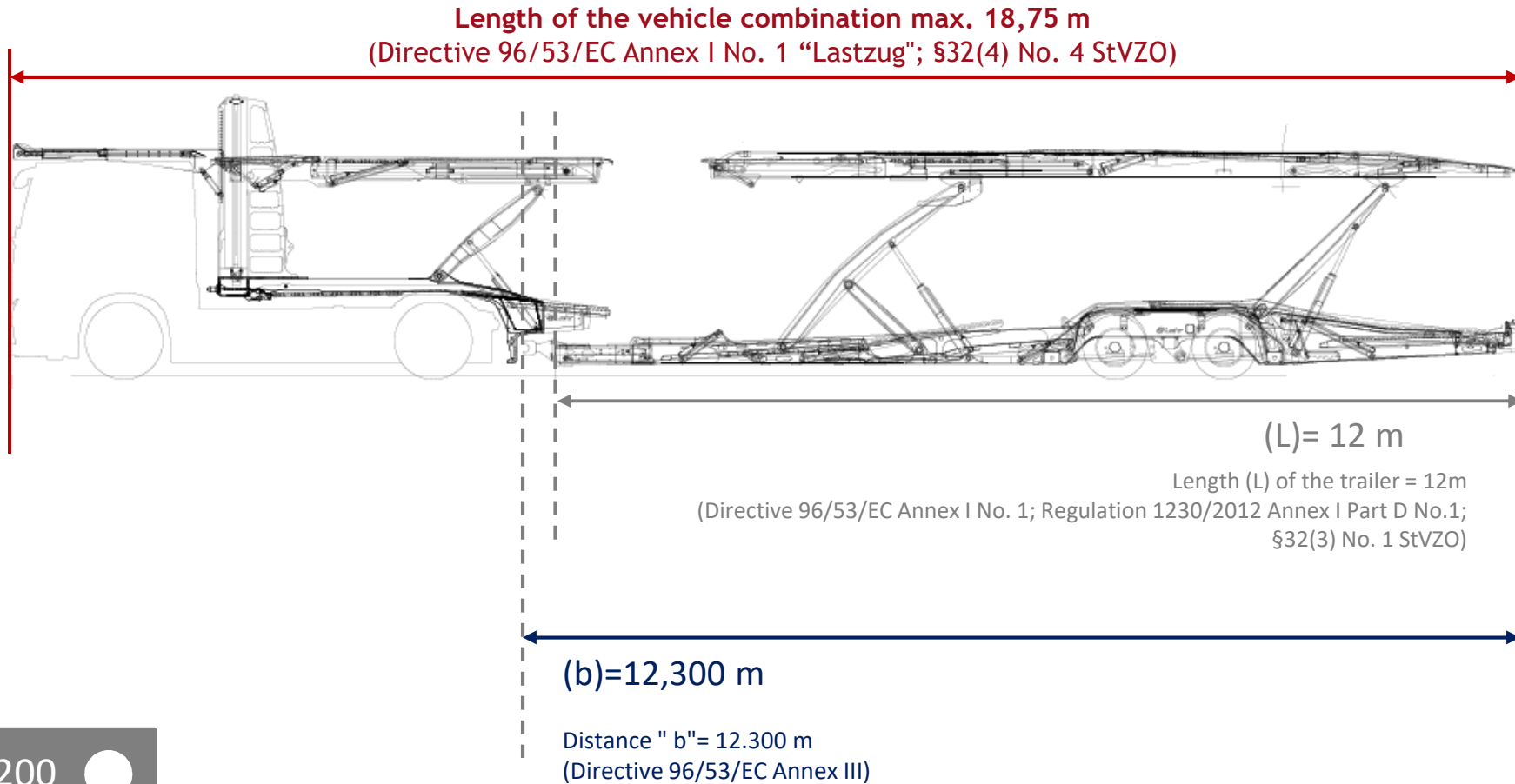

Series built from 2020

DIMENSIONS OF THE TRAILER AND VEHICLE COMBINATION

No. of EU type approval: e2*2007/46*0329*06

"The vehicle type meets the technical requirements of all the relevant acts specified in Annex IV to Directive 2007/46/EC."

Annex IV, point 48/48A: Regulation (EU) No 1230/2012

Length of the vehicle combination max. 18,75 m
(Directive 96/53/EC Annex I No. 1 "Lastzug"; §32(4) No. 4 StVZO)

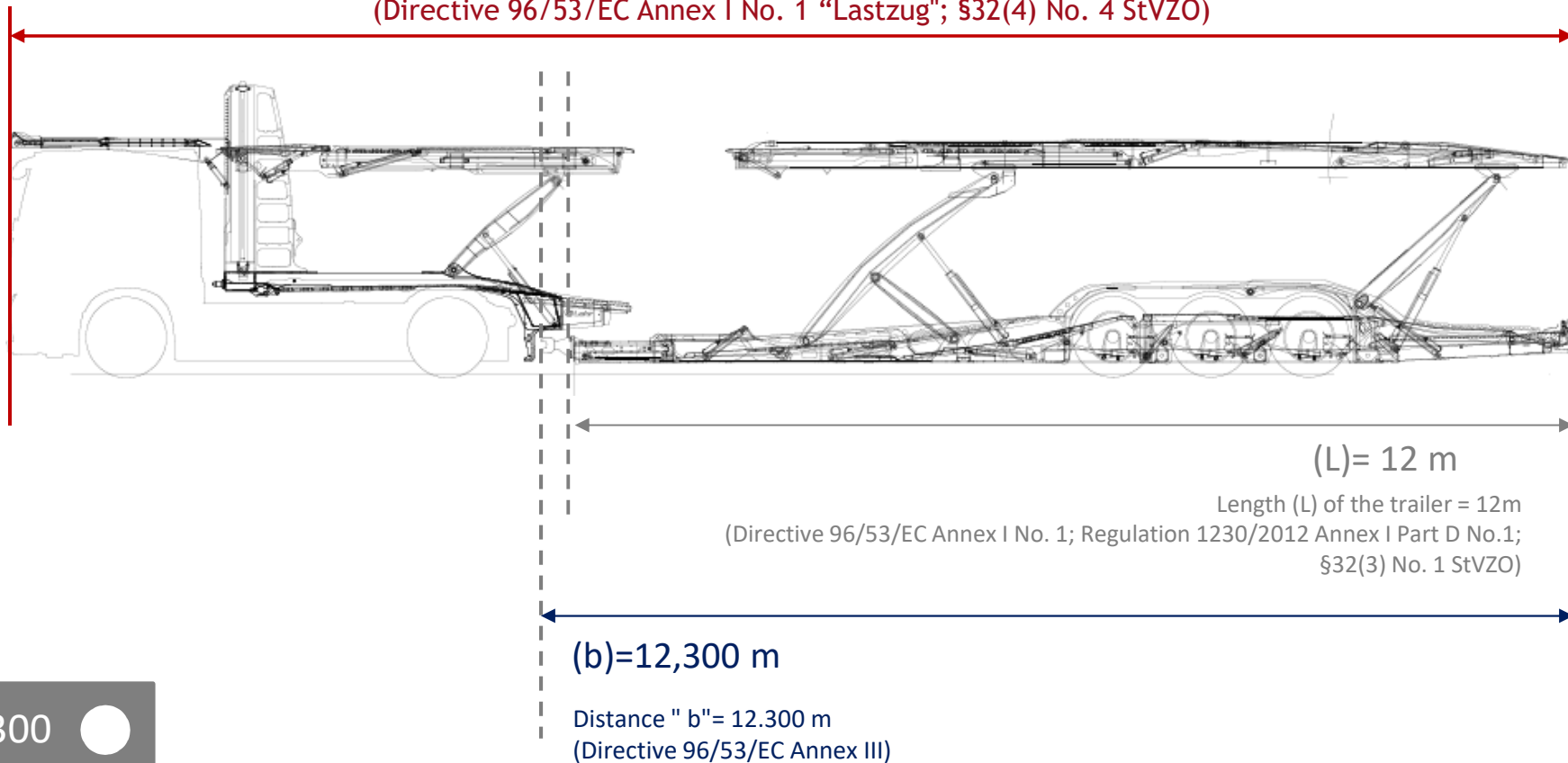

EHR 300



Series Built from 2020



GERMAN StVZO CLARIFICATION

USE OF THE UPPER LOADING PLATFORM FOR REAR CARGO OVERHANG

USE* OF THE UPPER REAR LOADING PLATFORM [1/2]

Updated information on the use of the material taking into account the clarification of 15.01.2020

EU (except in Germany)

LF 8
Example

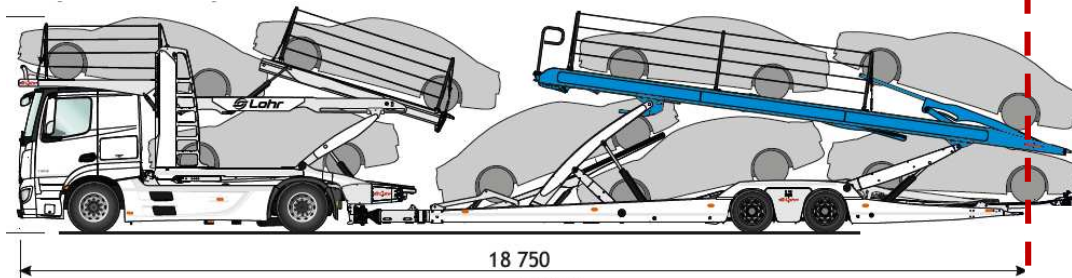

EU except in Germany:
Legal situation and use
of vehicles unchanged

LF 9
Example

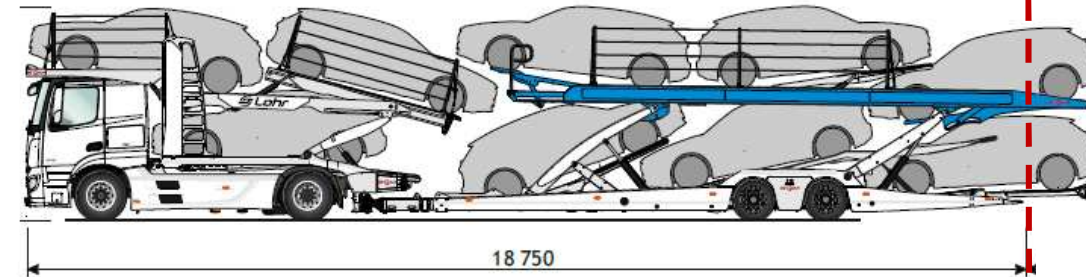

Germany Clarification of 15.01.2020 – previous series**

LF 8
Example

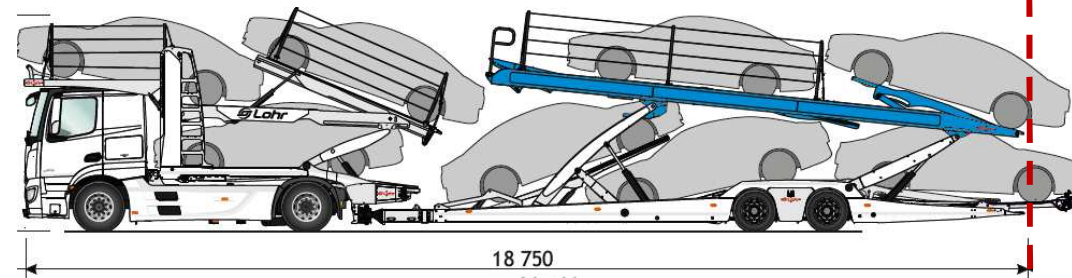

Germany:
(...) main loading areas
(...) cannot be
considered as loading
supports (...)

**Exception: EHR100 up to series 2008 (KBA approval)

*The compliance with all legal regulations within the scope of the effective use of the material is the responsibility of the transport company, excluding any liability of the manufacturer

USE* OF THE UPPER REAR LOADING PLATFORM [2/2]

(...) It must be possible to change the position of the loading support independently of the loading area; the loading supports may accordingly:

1. be removable, or
2. be permanently attached to the vehicle

Germany Use of independent loading supports as per clarification of 15.01.2020 – Earlier existing series (manual ramps)

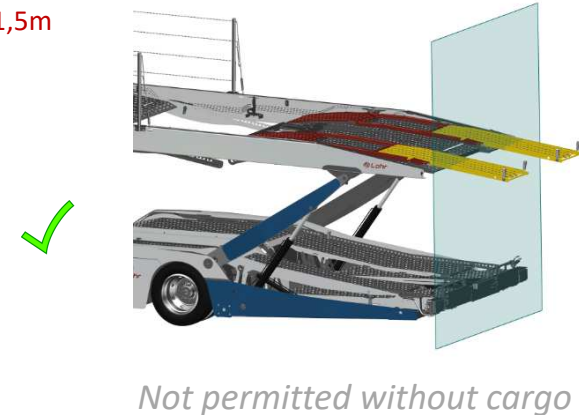
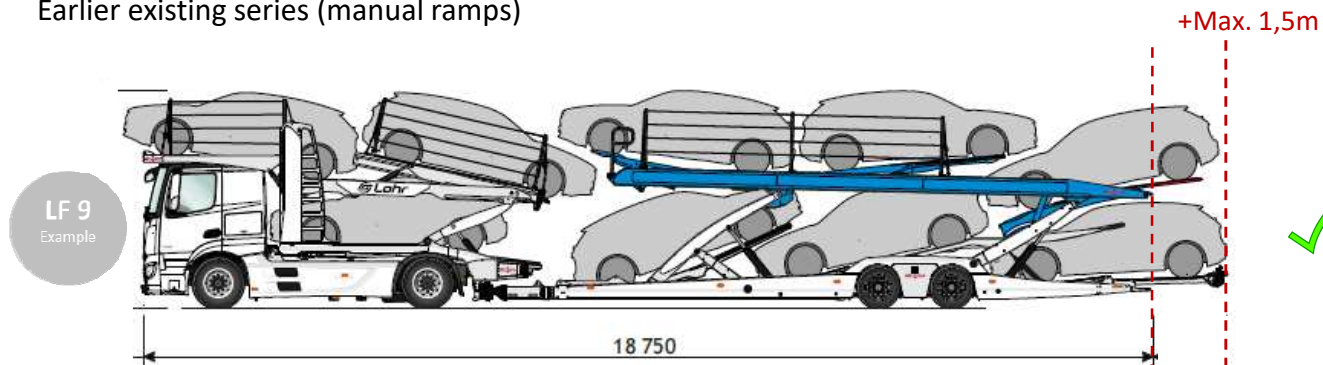

Germany Use of independent loading supports as per clarification of 15.01.2020 – New series (K2 SE+)

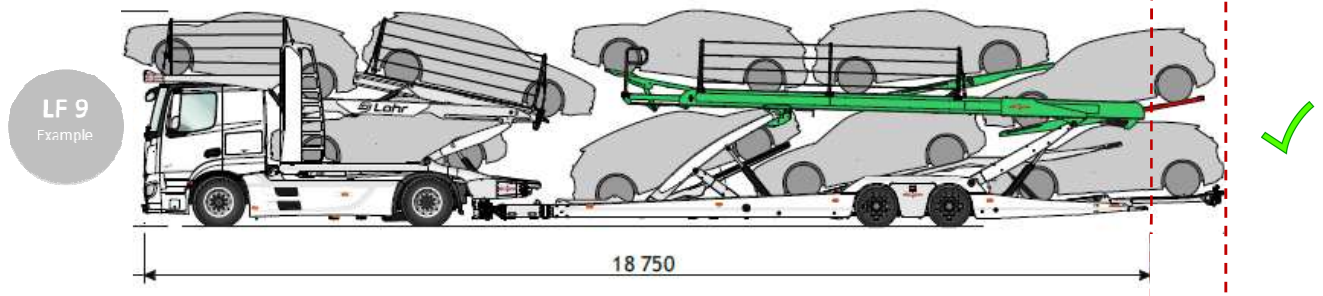

*The compliance with all legal regulations within the scope of the effective use of the material is the responsibility of the transport company, excluding any liability of the manufacturer

